

How To Solvent Cement Joint PVC Pipes

By Pipeline Percy

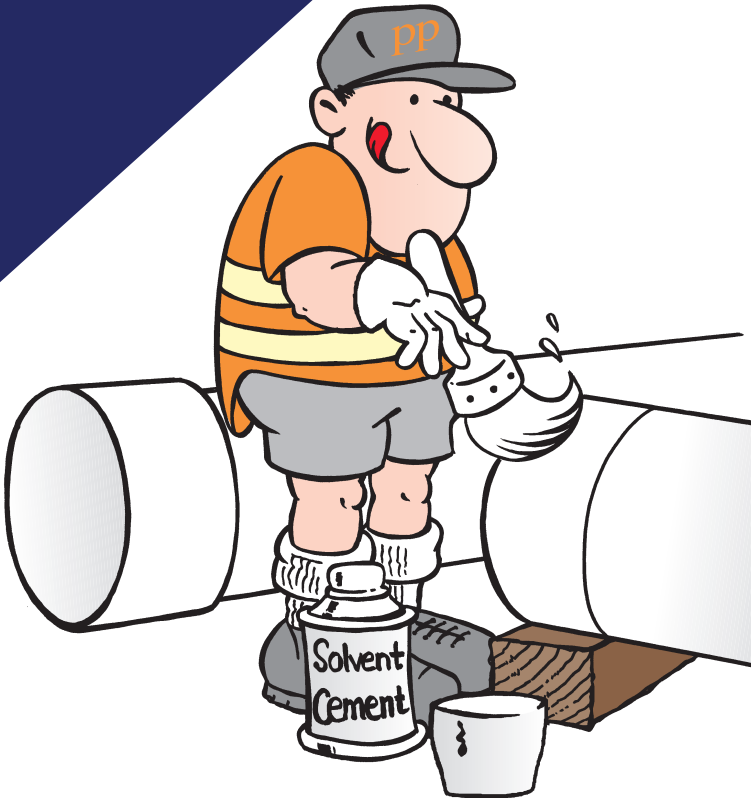

Introduction

G'day, I'm Pipeline Percy...

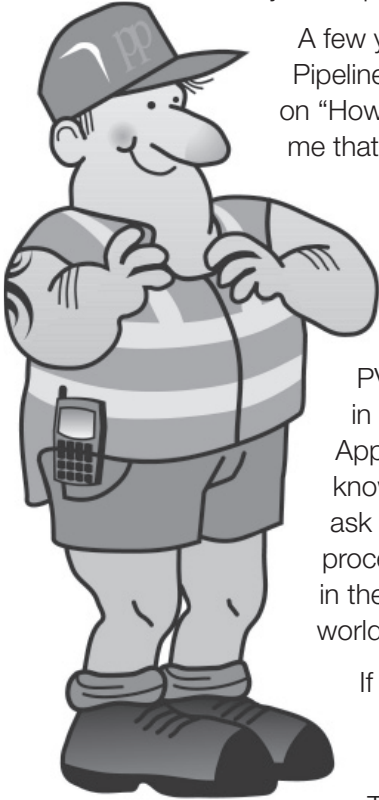

A few years ago the people at Iplex Pipelines asked me to write a book on "How I Install PVC Pipes". They tell me that it went down really well and I have become an overnight star!

They asked me to write another book on "How I Solvent Cement Joint PVC Pipes", correctly – adding in much more fine detail. Apparently some operators don't know how to do it and they always ask Iplex for help. I have based the procedure on what I know works in the field, I also researched the world to see how others do it too.

If followed, these guidelines will help you to get it right and to help you do it right – first time!

There are other places that you can go to download Standards and Guidelines too. I will mention those along the way.....

I hope this helps you.....

Pipeline Percy

Solvent Cement Jointing Guidelines for PVC pipes

1. Recommendations for use of NOVAKEY PVC Cleaner Primer and Solvent Cement

These recommendations apply generally to Apollo Series 1 PVC-O pipes, White Rhino (Series 1) PVC-M pipes, Novakey (Series 1) PVC-U pipes, Novadrain PVC-U DWV pipes, Novafuse PVC-F Fusible PVC Pipe, Superstorm PVC- U Pipe, and compatible Novakey or Novadrain PVC-U fittings.

The complete “Recommendations for Use”, printed on each container of Novakey Cleaner Primer, and Novakey PVC solvent cement and the recommendations for use contained in these guidelines must be adhered to.

1.1 Industry Guideline Documents

I strongly recommend you read other published documents including:

Plastic Industry Pipe Association (PIPA).

– Guidelines for Solvent Cement Jointing of PVC pipe;

<http://www.pipa.com.au/PDFs/POP102.pdf>

Australia New Zealand Standard.

– AS/NZS 2032 Installation of PVC Pipe Systems.

Novakey Cleaner Primer and Solvent Cement must be used together with Iplex PVC pipe, to ensure permanent leak free joints.

1.2 Use of Cleaner Primer

Cleaner primer **must be** used to prime and clean all jointing surfaces, prior to application of solvent cement. **NO EXCEPTIONS.** Cleaner primer softens the surface and is essential to a successful jointing process.

Do not prepare the surface using sand paper as contamination can occur.

Refer to **Table 1** for recommended use volumes.

1.3 Solvent Cement

No additive of any kind should be introduced to the cleaner primer, or to the solvent cement. Ensure that the solvent cement is in good condition and runs freely from the brush. If the cement does not run freely or appears “globular” or “tacky”, discard and use fresh stock of solvent cement. Ensure that the cement is within its recommended “use by” date.

Refer to **Table 1** for recommended use volumes.

1.4 Applicator Size

Use a brush or dauber that is properly sized for the pipe or fittings you are joining. The applicator width should be approximately 50% of the pipe diameter. Disposable brushes are recommended for pipe diameters larger than 100mm.

Refer to **Table 2** for recommended brush widths.

1.5 Basic Principles of Solvent Cement Welding

1.5.1 The joint surfaces must be softened and remain wet with solvent cement during joint assembly.

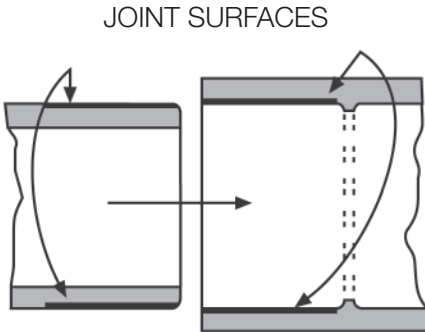

1.5.2 Sufficient solvent cement must be applied to fill the gap between the pipe and fitting.

SUFFICIENT CEMENT COATING

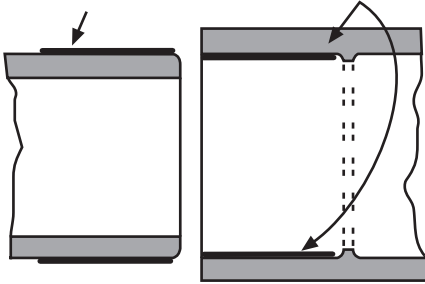

1.5.3 Assembly must be made while the surfaces are still wet and the solvent cement is still fluid.

SURFACES MUST BE ASSEMBLED WHILE THEY ARE STILL WET AND SOFT

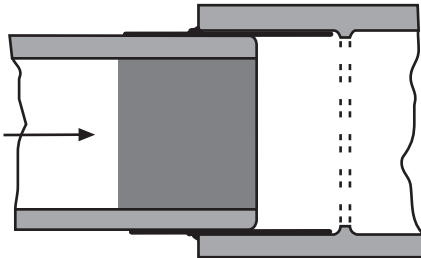

1.5.4 Joint strength develops as the solvents evaporate from the joint.

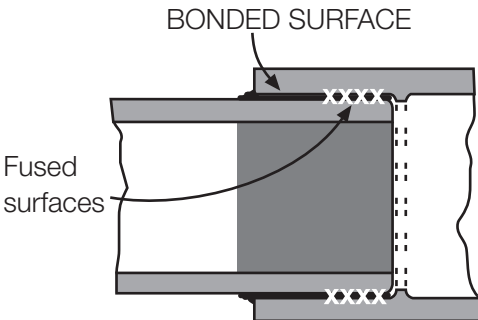

Fused and bonded surfaces of joined pipe and fitting

1.6 Low Temperature Solvent Cement Jointing

In cold weather conditions, solvents penetrate and soften the PVC surfaces much slower. Therefore, it is more important to pre-soften the jointing surfaces with cleaner primer. Because of slower evaporation of the solvents a longer cure time will be necessary.

1.7 Personal Protective Equipment (PPE)

We recommend the use of disposable polyethylene gloves when applying cleaner primer and solvent cement fluids.

When joining pipe and fittings, within confined spaces, ensure good ventilation is present or use of suitable breathing equipment.

1.8 Health and Safety Caution

Solvent cement and cleaner primer are highly inflammable liquids and should be kept away from all sources of ignition. They may be harmful if swallowed or inhaled and may cause skin or eye irritation. Avoid breathing the vapour, use in well ventilated areas.

Seek medical attention immediately, if:

Swallowed: Give water to dilute, do not cause vomiting.

Skin Contact: Remove contaminated clothing and wash skin thoroughly with soap and water.

Eye Contact: Hold open and flood with water for at least 15 minutes.

Do not contaminate any water supply.

Store containers in a cool place, dispose of empty containers safely.

We recommend that you comply with all warning and First Aid notices, displayed on container labels.

Table 1 Estimated Usage Guide

Number of joints for cleaner primer and solvent cement

Nominal Diameter DN	Cleaner Primer (500ml)	Solvent Cement (500ml)
15	1050	300
20	625	175
25	450	130
32	325	95
40	250	70
50	150	42
65	125	35
80	100	30
100	70	25
125	55	20
150	45	15
200	27	8
225	20	7
300	6	5
375	4	2

Table 2 Recommended Brush Widths

Pipe Nominal Diameter DN	Brush Width (mm)
100	50
125	75
150	80
200	100
225	125
300	150
375	200

2. PVC Pipe and Fitting Preparation

Step 1. Cut Spigot Square and Deburr

Cut pipe square, ensure the pipe spigot and socket are not damaged. Remove any burrs, sharp edges and pipe shavings from the spigot and socket using a file or reaming tool. Correct deburring of the spigot avoids displacement of the cement from the inside of the socket when the spigot is inserted to make the joint. Failure to correctly deburr may prevent full pipe penetration and/or cause the detrimental accumulation of solvent cement at the back of the joint.

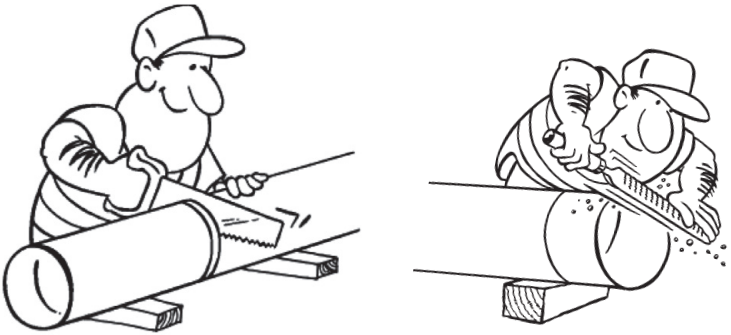

Step 2. Apply Witness Mark

Measure the insertion depth of the socket that you are about to join. On the spigot mark a corresponding witness mark with a pencil or felt pen.

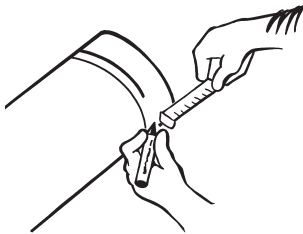

Step 3. Test – Dry Fit the Joint

Check the spigot and socket for an interference fit by dry fitting the joint. An interference fit must be reached between approximately $\frac{1}{3}$ - $\frac{2}{3}$ of the socket depth determined by the witness mark position.



Step 4. Applicator Selection

The brush should be large enough to apply the solvent cement within 30 seconds, a disposable brush is recommended for use. For pipes larger than 100mm, it may be necessary to decant solvent cement into a larger container to enable a large brush to be used.

Refer to Table 2 for recommended brush widths.



3. Solvent Cement Welding Procedure

Step 1. Inspect Clean and Prime Surfaces

Cleaner primer fluid **MUST BE** used to clean and prime all surfaces, it is essential to the jointing process. The primer etches the PVC surface, removes the gloss and softens for the solvent cement's effective bond.

Ensure the spigot and socket are clean and dry. Moisture contamination may lead to future joint failure.

Apply cleaner primer to the spigot and socket with a lint-free cloth (natural fibres) dampen the joint with priming fluid.

Use the correct personal protective equipment at all times.

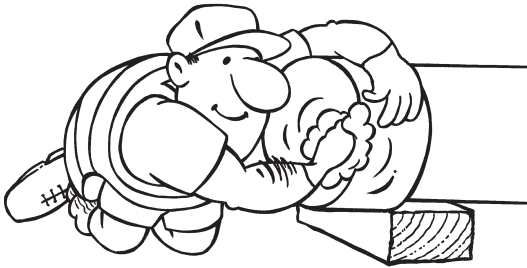

Step 2. Apply Solvent Cement

Using a suitably sized brush apply a full even coat of solvent cement (down to the witness mark) to the spigot and an even layer to the socket.

Apply a second full even coat to the spigot **if required**. Excessive solvent cement on the outer OD can easily be wiped away after assembly.

Ensure the **entire surface** is covered and are **“thoroughly wet”** with cement before assembly.

As solvents evaporate faster from the exposed spigot than from the socket a “dry” patch not lubricated by wet solvent cement, may also prevent full insertion.

Ensure that excess solvent cement **does not pond** at the back of the socket as pools of solvent may continue to attack the PVC and weaken the pipe.

Excess or un-used solvent cement should never be returned to the storage can.

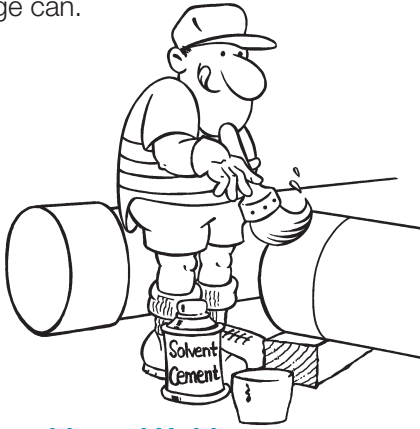

Step 3. Assemble and Hold

While the cement is still wet quickly (within 1 minute), push spigot into socket up to the witness mark. Make the joint in a single movement, push the assembly home firmly. **Do not stop** as the bond will start to set immediately.

The final 10% of spigot penetration **is vital** to the interference fit.

Hold the joint firmly without movement for at least 30 seconds.

Mechanical force will be required for larger joints, **be ready in advance**. Pipe pullers, polyester straps or come-alongs may be required, in order to apply a winch or lever hold-force.



Step 4. Excess Solvent Cement

A consistent bead must be visible at the mouth of the joint. Wipe off the excess solvent cement from the outside, and where possible from the inside of the pipe or fitting.



Step 5. Do Not Disturb Joint

Do not move the joint for at least **5 minutes**, and handle carefully for at least another hour after jointing.

Step 6. Joint Curing

Allow the cement to fully cure before attempting any site pressure testing.

Joint curing normally takes at least 24 hours @16-20°C. Allow up to 48 hours cure time if the temperature is less than 15°C.

Do not fill the pipe with water for at least one hour after making the last joint.

4. Pressure Testing

Once the joints have completely cured and when they are anchored correctly, you can then fill the pipe with water to complete a system pressure test.

Iplex have asked me to write another book on “How I Pressure Test Pipes” so watch out for that booklet too. In the meantime look for the pressure test procedure from your contract documents, council code of practices or follow the procedure in New Zealand’s NZS 4404 Land Development and Subdivision Infrastructure - Standard.

For Field Testing of Pipelines, go to Appendix C about three-quarters the way through the book. You need to follow the entire procedure starting at clause C1.

Well that’s it...its easy when you know how! Always do it right the first time....
Keep on joining ‘em pipes!



Pipeline Percy

Disclaimer:

The information, opinions, advice and recommendations contained in this publication are put forward with the main object of providing a better understanding of technical matters associated with pipeline and component design using Iplex Pipelines. Whilst all reasonable care has been made in ensuring that the information contained in this publication is accurate, this publication should not be used as the only source of information by the reader. Reference should also be made to establish textbooks and other published material, and readers should not rely on the information contained in this publication without taking appropriate professional advice for their particular circumstances. Fittings have been shown as typical configurations, however, in some cases product dimensions or installations may vary or be changed without notice. In all instances, the reader should contact Iplex Pipelines for clarification that the specific product is appropriate for their circumstances.



Iplex Pipelines NZ Ltd
67 Malden Street, Palmerston North.

Contact our Call Centre for further advice on
0800 800 262